Product Specification

320240H SERIES

Customer:
Approved by:

Approved by	Checked by	Prepared by

RECORDS OF REVISION

Part Number	Revision	Revision Content	Revised on
320240H	00	First issue	Oct. 20th, 2016

CONTENTS

1. FUNCTIONS & FEATURES	3
2. MECHANICAL SPECIFICATIONS	3
3. EXTERNAL DIMENSIONS	4
4. BLOCK DIAGRAM.....	5
5. PIN ASSIGNMENT	5
6. ABSOLUTE MAXIMUM RATINGS(VSS=0V, TA=25°C)	6
7. ELECTRICAL CHARATERISTICS	6
8. COMMAND DEFINITIONS	10
9. OPTICAL CHARACTERISTICS	11
10. RELIABILITY TEST	13
11. INSPECTION SPECIFICATION	14
12. LCD MODULES HANDLING PRECAUTIONS.....	17
13. OTHERS	17

1. FUNCTIONS & FEATURES

- Viewing Direction : 6 O'clock
- Driving Scheme : 1/240Duty, 1/17 Bias
- Power Supply for logic : 5.0V
- Backlight Color : White
- Display Content : 320 x 240 Dots
- V_{LCD} : 23.0V
- Driver IC : NT7086
- Controller IC : RA8835
- RoHS Conformed

2. MECHANICAL SPECIFICATIONS

- Module Size : 148.60(L) x 120.24(W) x 13.00(H)MAX mm
- Viewing Area : 122.00(L)mm x 92.00 (W)mm
- Active Area : 115.18(L)mm x 63.38 (W)mm
- Dot Pitch : 0.36 (W)mm x 0.36 (H)mm
- Dot Size : 0.34 (W)mm x 0.34 (H)mm
- Dot Gap : 0.02 mm

3. EXTERNAL DIMENSIONS

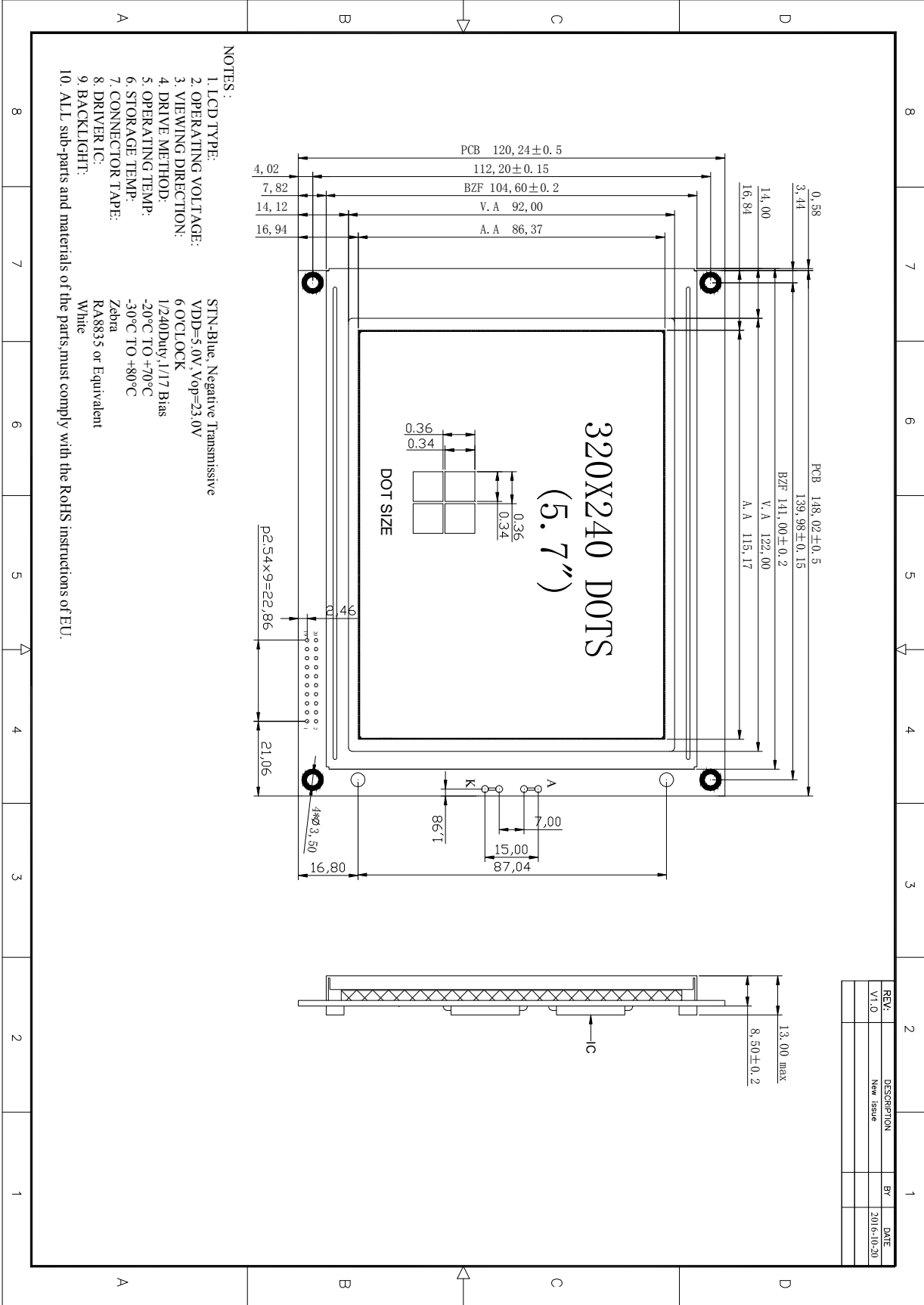

REV.	DESCRIPTION	BY	DATE
V1.0	New Issue		2016-10-20

4. BLOCK DIAGRAM

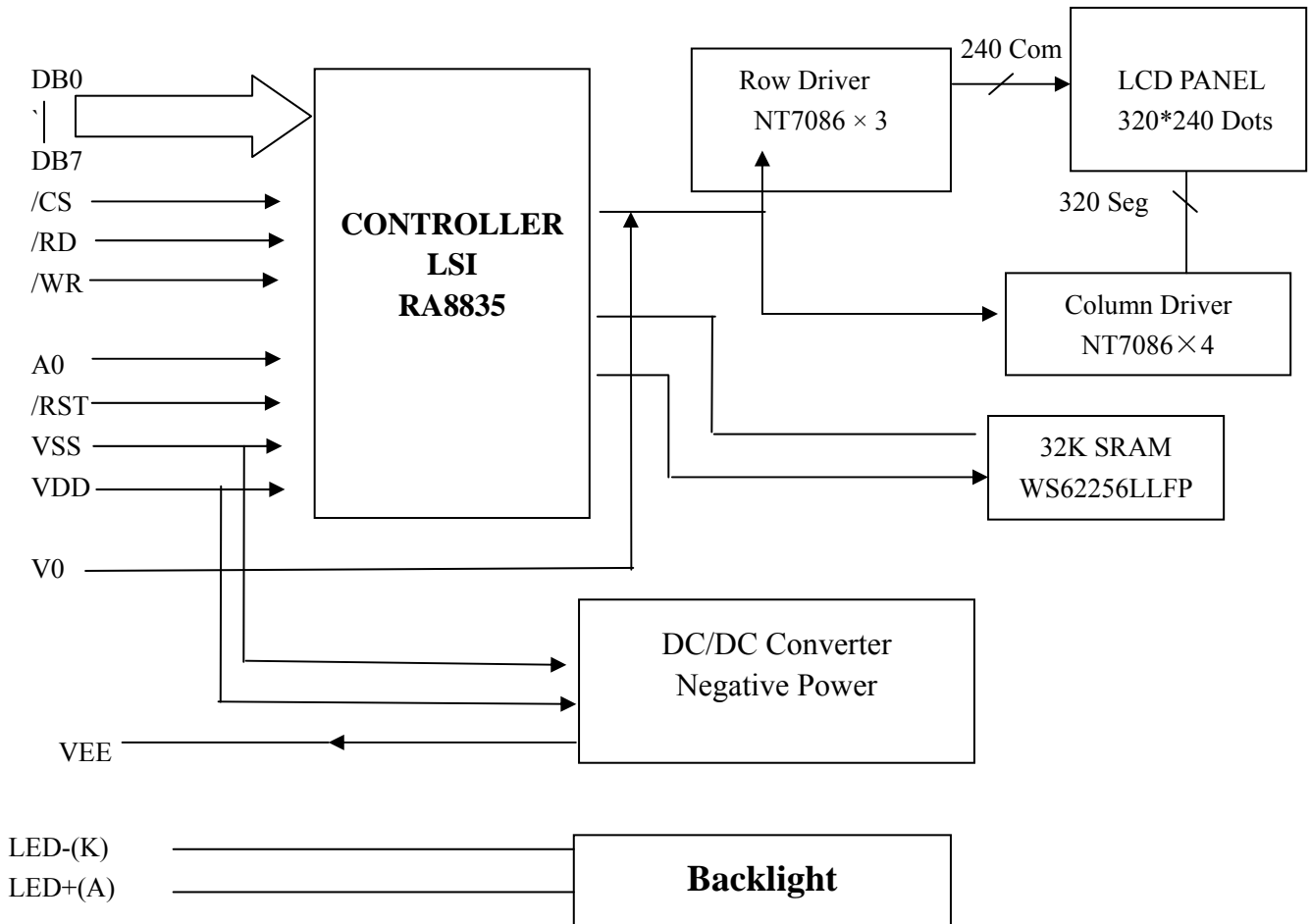

5. PIN ASSIGNMENT

Pin No	Symbol	Description	
1	VSS	Power Supply(VSS=0)	
2	VDD	Supply voltage for logic(VDD>VSS)	
3	V0	Operating voltage for LCD;Not connecting	
4	RD\	Read Signal	
5	WR\	Write Signal	
6	A0	Data Type Selection	
7	DB0	Data BUS	
8	DB1	Data BUS	
9	DB2	Data BUS	
10	DB3	Data BUS	
11	DB4	Data BUS	
12	DB5	Data BUS	
13	DB6	Data BUS	
14	DB7	Data BUS	
15	CS\	Chip select Signal	
16	RES\	Reset Signal	
17	VEE	Negative voltage supply;Not connection	
18	FG	Frame ground	
19	LED+	LED Back light Power +5V	
20	LED-	LED Back light Power 0V	

Product Specification

6. ABSOLUTE MAXIMUM RATINGS($V_{SS}=0V$, $T_a=25^{\circ}C$)

Parameter	Symbol	Rating	Unit
Supply voltage range	V_{DD}	-0.3 to 7.0	V
Input voltage range	V_{IN}	-0.3 to $V_{DD}+ 0.3$	V
Power dissipation	P_D	300	mW
Operating temperature range	T_{opg}	-20 to 75	$^{\circ}C$
Storage temperature range	T_{stg}	-65 to 150	$^{\circ}C$
Soldering temperature (10 seconds). See note 1.	T_{solder}	260	$^{\circ}C$

Notes:

1. The humidity resistance of the flat package may be reduced if the package is immersed in solder. Use a soldering technique that does not heatstress the package.
2. If the power supply has a high impedance, a large voltage differential can occur between the input and supply voltages. Take appropriate care with the power supply and the layout of the supply lines.

7. ELECTRICAL CHARACTERISTICS

1). DC Characteristics

$T_a=25^{\circ}C$, $V_{SS}=0V$

Parameter	Symbol	Condition	Rating			Unit
			Min.	Typ.	Max.	V
Supply voltage	V_{DD}		4.5	5.0	5.5	V
Register data retention voltage	V_{OH}		2.0	—	6.0	V
Input leakage current	I_{LI}	$V_I = V_{DD}$. See note 5.	—	0.05	2.0	μA
Output leakage current	I_{LO}	$V_I = V_{SS}$. See note 5.	—	0.10	5.0	μA
Operating supply current	I_{opr}	See note 4.	—	3.5	8	mA
Quiescent supply current	I_Q	Sleep mode, $V_{OSC1} = V(\overline{CS}) = V(\overline{RD}) = V_{DD}$	—	0.05	20.0	μA
Oscillator frequency	f_{osc}	Measured at crystal, 47.5% duty cycle. See note 6.	1.0	—	18.0	MHz
External clock frequency	f_{CL}		1.0	—	18.0	MHz
Oscillator feedback resistance	R_f		0.5	1.0	3.0	$M\Omega$

2). AC Characteristics

8080 Family Interface Timing

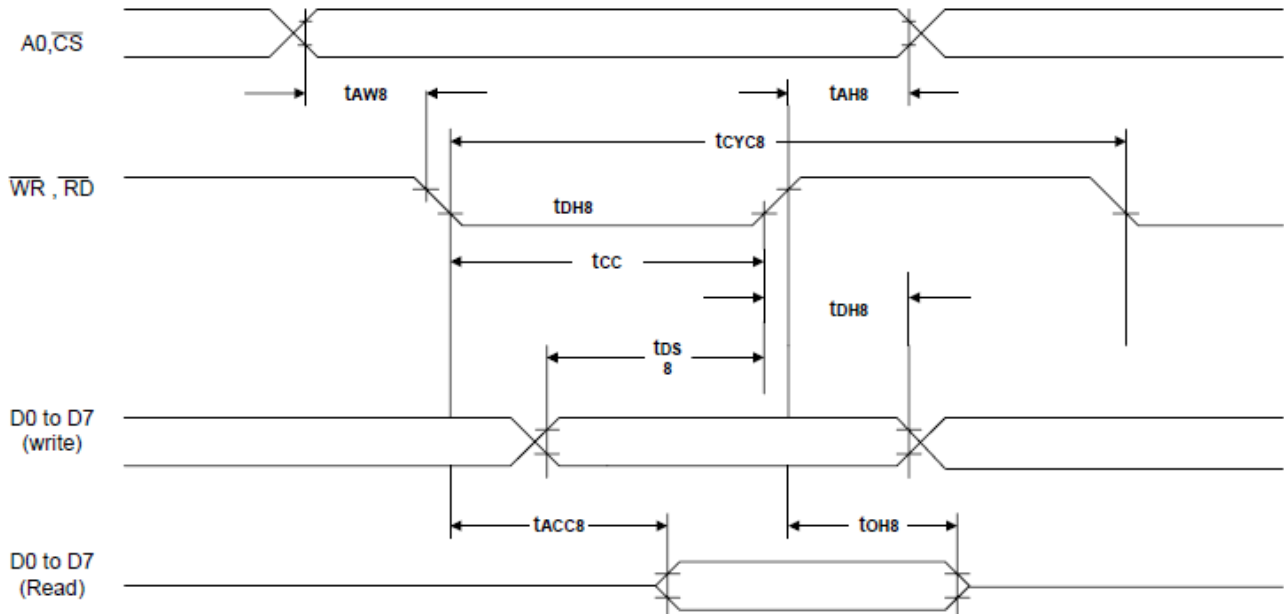

Signal	Symbol	Parameter	$V_{DD} = 4.5 \text{ to } 5.5V$		$V_{DD} = 2.7 \text{ to } 4.5V$		Unit	Condition
			Min.	Max.	Min.	Max.		
A0, \overline{CS}	t_{AH8}	Address hold time	10	—	10	—	ns	CL = 100pF
	t_{AW8}	Address setup time	0	—	0	—	ns	
\overline{WR} , \overline{RD}	t_{CYC8}	System cycle time	note.	—	note.	—	ns	
	t_{CC}	Strobe pulse width	120	—	150	—	ns	
D0 to D7	t_{DS8}	Data setup time	120	—	120	—	ns	
	t_{DH8}	Data hold time	5	—	5	—	ns	
	t_{ACC8}	\overline{RD} access time	—	50	—	80	ns	
	t_{OH8}	Output disable time	10	50	10	55	ns	

Note: For memory control and system control commands:

$$t_{CYC8} = 2t_c + t_{CC} + t_{CEA} + 75 > t_{ACV} + 245$$

For all other commands:

$$t_{CYC8} = 4t_c + t_{CC} + 30$$

6800 Family Interface Timing

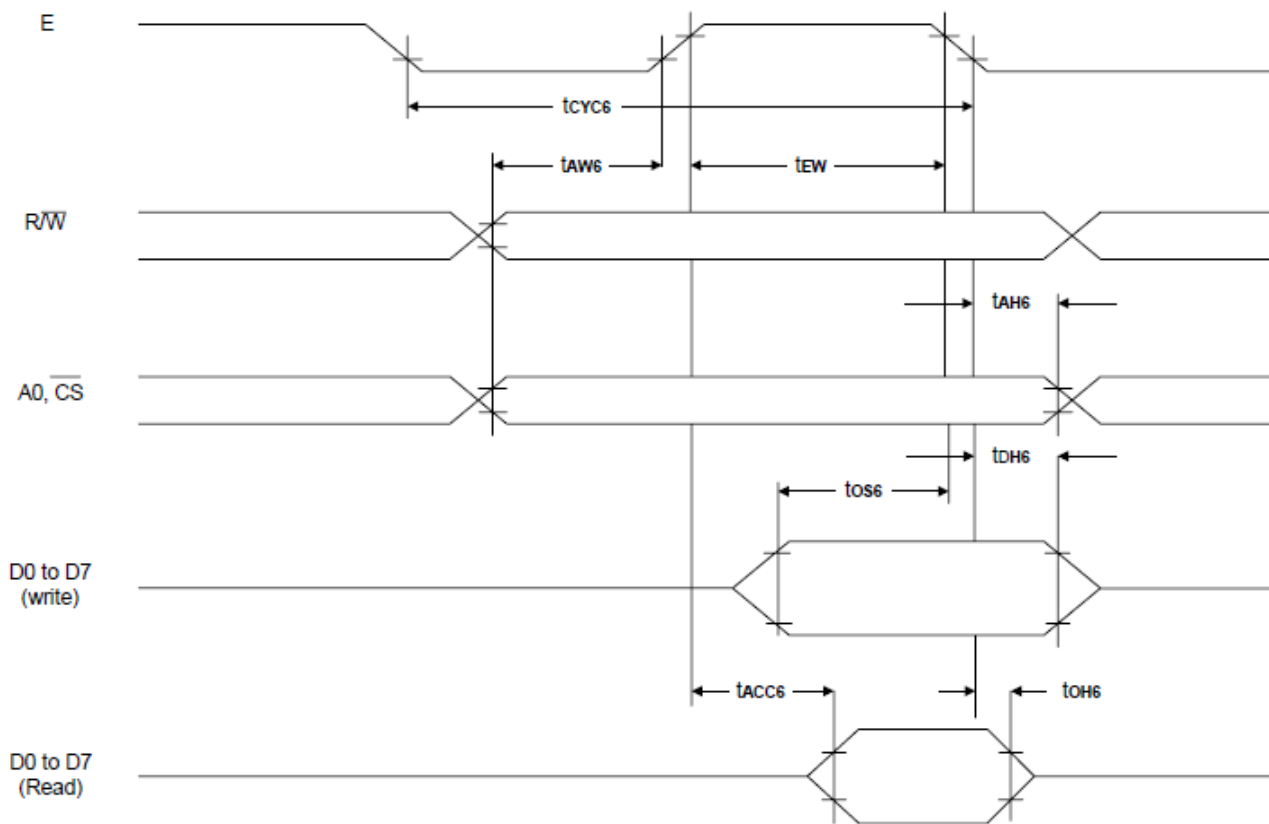

Signal	Symbol	Parameter	$V_{DD} = 4.5 \text{ to } 5.5V$		$V_{DD} = 2.7 \text{ to } 4.5V$		Unit	Condition
			Min.	Max.	Min.	Max.		
A0, \overline{CS} , R/(W)	t_{CYC6}	System cycle time	note.	—	note.	—	ns	CL = 100 pF
	t_{AW6}	Address setup time	0	—	10	—	ns	
	t_{AH6}	Address hold time	0	—	0	—	ns	
D0 to D7	t_{DS6}	Data setup time	100	—	120	—	ns	
	t_{DH6}	Data hold time	0	—	0	—	ns	
	t_{OH6}	Output disable time	10	50	10	75	ns	
	t_{ACC6}	Access time	—	85	—	130	ns	
E	t_{EW}	Enable pulse width	120	—	150	—	ns	

Note: For memory control and system control commands:

$$t_{CYC6} = 2t_C + t_{EW} + t_{CEA} + 75 > t_{ACV} + 245$$

For all other commands:

$$t_{CYC6} = 4t_C + t_{EW} + 30$$

Sleep In Command Timing

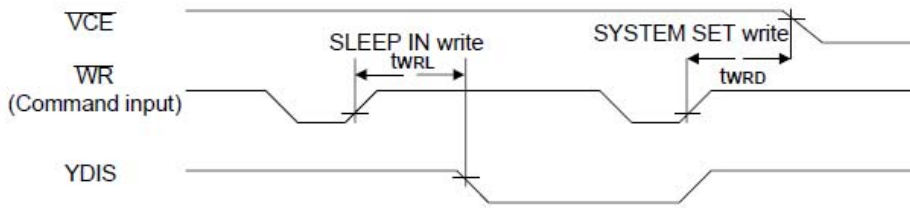

Ta = -20 to 75°C

Signal	Symbol	Parameter	V _{DD} = 4.5 to 5.5V		V _{DD} = 2.7 to 4.5V		Unit	Condition
			Min.	Max.	Min.	Max.		
$\overline{\text{WR}}$	t _{WRD}	VCE falling-edge delay time	note 1.	—	note 1.	—	ns	CL = 100 pF
	t _{WRL}	YDIS falling-edge delay time	—	note 2.	—	note 2.	ns	

Notes:

1. $t_{\text{WRD}} = 18t_{\text{C}} + t_{\text{OSS}} + 40$ (t_{OSS} is the time delay from the sleep state until stable operation)
2. $t_{\text{WRL}} = 36t_{\text{C}} \times [\text{TC/R}] \times [\text{L/F}] + 70$

8. COMMAND DEFINITIONS

Class	Command	Code											Command Description	
		RD	WR	A0	D7	D6	D5	D4	D3	D2	D1	D0		
System control	SYSTEM SET	1	0	1	0	1	0	0	0	0	0	0	0	Initialize device and display
	SLEEP IN	1	0	1	0	1	0	1	0	0	1	1	Enter standby mode	
Display control	DISP ON/OFF	1	0	1	0	1	0	1	1	0	0	D	Enable and disable display and display flashing	
	SCROLL	1	0	1	0	1	0	0	0	1	0	0	Set display start address and display regions	
	CSRFORM	1	0	1	0	1	0	1	1	1	0	1	Set start address of character generator RAM	
	CGRAM ADR	1	0	1	0	1	0	1	1	1	0	0	Set direction of cursor movement	
	CSRDIR	1	0	1	0	1	0	0	1	1	CD1	CD0	Set direction of cursor movement	
	HDOT SCR	1	0	1	0	1	0	1	1	0	1	0	Set horizontal scroll position	
	OVLAY	1	0	1	0	1	0	1	1	0	1	1	Set display overlay format	
Drawing control	CSRW	1	0	1	0	1	0	0	0	1	1	0	Set cursor address	
	CSRR	1	0	1	0	1	0	0	0	1	1	1	Read cursor address	
Memory control	MWRITE	1	0	1	0	1	0	0	0	0	1	0	Write to display memory	
	MREAD	1	0	1	0	1	0	0	0	0	1	1	Read from display memory	

9. OPTICAL CHARACTERISTICS

9.1 Definition of Viewing Angle

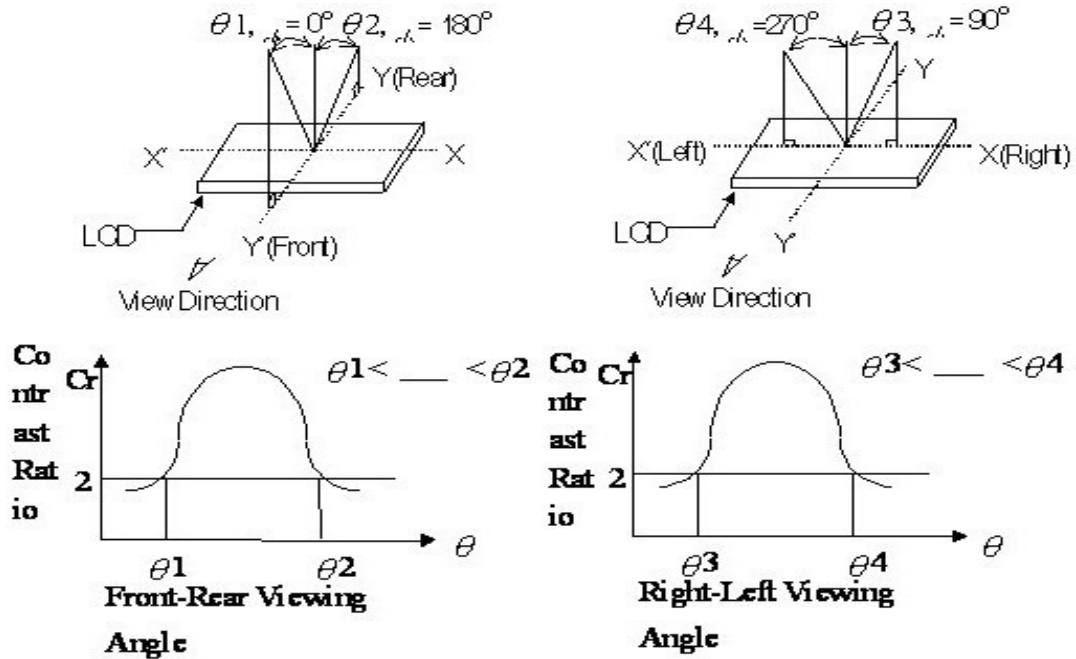

9.2 Definition of Contrast

$$C.R = \frac{\text{Brightness of nonselected segment (E2)}}{\text{Brightness of selected segment}}$$

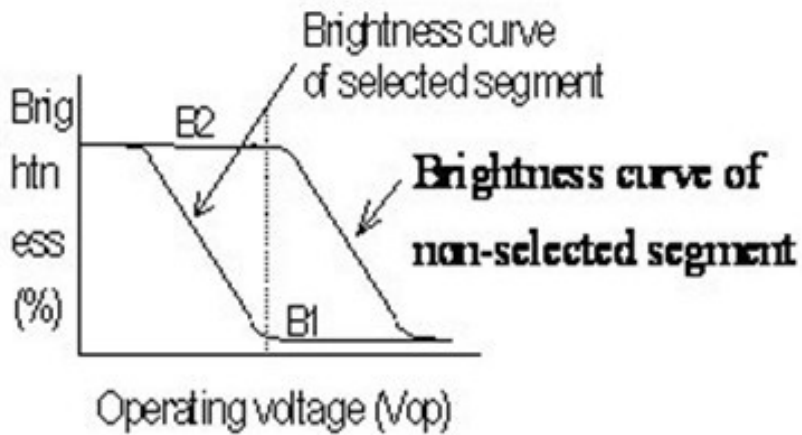

9.3 Definition of Response

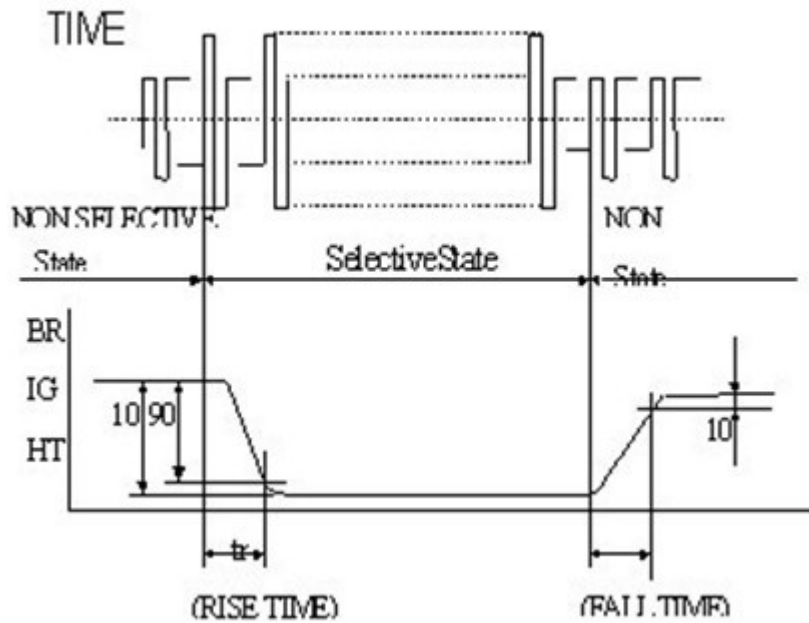

9.4 Measuring Instruments For Electro-optical Characteristics

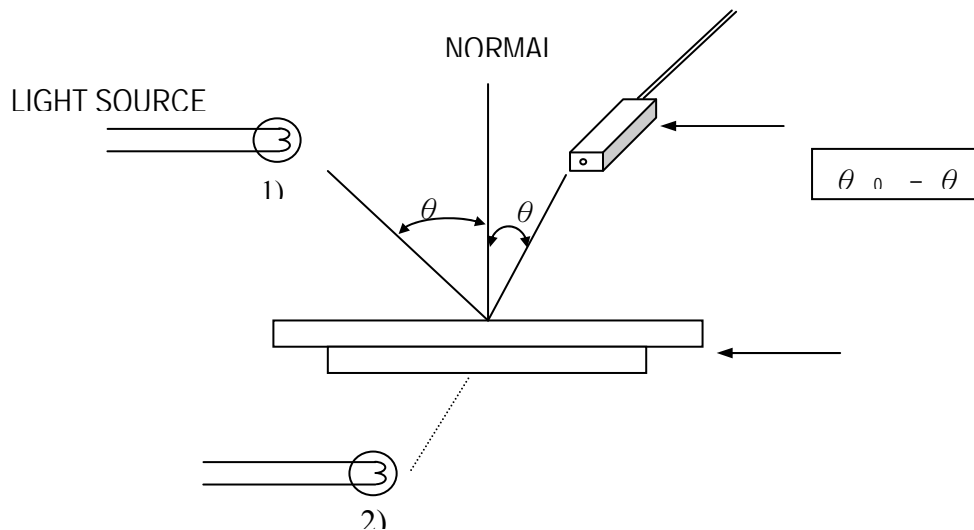

*** Note:**

- 1) Light source position for measuring the reflective type of LCD panel;
- 2) Light source position for measuring the transmissive / transmissive types of LCD panel.

Product Specification

10. RELIABILITY TEST

Operating life time: Longer than 50,000 hours

(at room temperature without direct irradiation of sunlight)

Reliability characteristics shall meet following requirements.

No.	Test Item	Content of Test	Test Condition
1	High Temperature Storage	Endurance test applying the high storage temperature for a long time	+80°C 96H
2	Low Temperature Storage	Endurance test applying the low storage temperature for a long time	-30°C 96H
3	High Temperature Operation	Endurance test applying the electric stress (voltage & current) and the thermal stress to the element for a long time	+70°C 96H
4	Low Temperature Operation	Endurance test applying the electric stress under low temperature for a long time	-20°C 96H
5	High Temperature/ Humidity Storage	Endurance test applying the high temperature and humidity storage for a long time	40°C 90%RH 96H
6	Temperature Cycle	Endurance test applying the low and high temperature cycle $ \begin{array}{ccccccc} -20^{\circ}\text{C} & \longleftrightarrow & 25^{\circ}\text{C} & \longleftrightarrow & 70^{\circ}\text{C} & \longleftrightarrow & 25^{\circ}\text{C} \\ 30\text{min} & & 5\text{min} & & 30\text{min} & & 5\text{min} \\ \longleftarrow & & & & & & \longrightarrow \\ & & & & & & \text{1 cycle} \end{array} $	-20°C/70°C 5 cycles
7	Vibration Test (Package State)	Endurance test applying the vibration during transportation	10Hz—55Hz, 50m/s, 15min
8	Shock Test (Package State)	Endurance test applying the shock during transportation	Half-sinewave, 100m/s, 11ms
9	Atmospheric Pressure Test	Endurance test applying the atmospheric pressure during transportation by air	40 kPa 16 H

11. Inspection specification

11.1 Visual Inspection

- 1) Inspect under 2x20W or 40W fluorescent lamp (approximately 3000 lux) leaving 25 to 30 cm between the module and the lamp and 30 cm between the module and the eye (measuring position).
- 2) Appearance is inspected at the best contrast voltage (best contrast is adjusted considering clearness and crosstalk on screen).
- 3) Inspect the module at 45° right and left, top and bottom.
- 4) Use the optimum viewing angle during the contrast inspection.

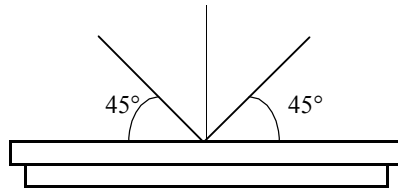

12.2 Standard of Appearance Inspection

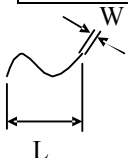
No.	Item	Criteria																																			
1	Black spot	<p>Round type: as per following drawing $\Phi = (X+Y)/2$</p>  <table border="1" style="margin-left: auto; margin-right: auto;"> <thead> <tr> <th colspan="3">Acceptable quantity</th> </tr> <tr> <th>Size</th> <th>Zone A</th> <th>Zone B</th> </tr> </thead> <tbody> <tr> <td>$\Phi < 0.1$</td> <td>Any number</td> <td rowspan="4" style="text-align: center;">Any number</td> </tr> <tr> <td>$0.1 < \Phi < 0.2$</td> <td style="text-align: center;">2</td> </tr> <tr> <td>$0.2 < \Phi < 0.25$</td> <td style="text-align: center;">1</td> </tr> <tr> <td>$0.25 < \Phi$</td> <td style="text-align: center;">0</td> </tr> </tbody> </table> <p>Line type: as per following drawing</p> <table border="1" style="margin-left: auto; margin-right: auto;"> <thead> <tr> <th colspan="4">Acceptable quantity</th> </tr> <tr> <th>Length</th> <th>Width</th> <th>Zone A</th> <th>Zone B</th> </tr> </thead> <tbody> <tr> <td style="text-align: center;">—</td> <td style="text-align: center;">$W \leq 0.02$</td> <td style="text-align: center;">Any number</td> <td rowspan="4" style="text-align: center;">Any number</td> </tr> <tr> <td style="text-align: center;">$L \leq 3.0$</td> <td style="text-align: center;">$0.02 < W \leq 0.03$</td> <td rowspan="2" style="text-align: center;">2</td> </tr> <tr> <td style="text-align: center;">$L \leq 2.5$</td> <td style="text-align: center;">$0.03 < W \leq 0.05$</td> </tr> <tr> <td style="text-align: center;">—</td> <td style="text-align: center;">$0.05 < W$</td> <td style="text-align: center;">As round type</td> </tr> </tbody> </table>  <p>Total acceptable quantity: 3</p>	Acceptable quantity			Size	Zone A	Zone B	$\Phi < 0.1$	Any number	Any number	$0.1 < \Phi < 0.2$	2	$0.2 < \Phi < 0.25$	1	$0.25 < \Phi$	0	Acceptable quantity				Length	Width	Zone A	Zone B	—	$W \leq 0.02$	Any number	Any number	$L \leq 3.0$	$0.02 < W \leq 0.03$	2	$L \leq 2.5$	$0.03 < W \leq 0.05$	—	$0.05 < W$	As round type
	Acceptable quantity																																				
Size	Zone A	Zone B																																			
$\Phi < 0.1$	Any number	Any number																																			
$0.1 < \Phi < 0.2$	2																																				
$0.2 < \Phi < 0.25$	1																																				
$0.25 < \Phi$	0																																				
Acceptable quantity																																					
Length	Width	Zone A	Zone B																																		
—	$W \leq 0.02$	Any number	Any number																																		
$L \leq 3.0$	$0.02 < W \leq 0.03$	2																																			
$L \leq 2.5$	$0.03 < W \leq 0.05$																																				
—	$0.05 < W$	As round type																																			
	White spot																																				
	Dust																																				
2	Polariser scratch	Scratch on protective film is permitted Scratch on polariser: same as No. 1																																			
3	Polariser bubble	$\Phi = (X+Y)/2$																																			

Product Specification

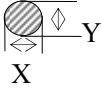
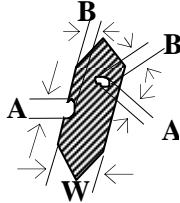
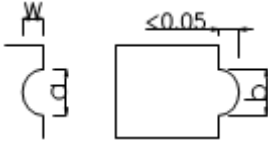
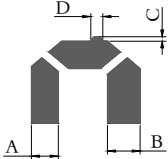
		 <p>Total acceptable quantity: 3</p>																										
4	Segment deformation	<p>4.1 Pin hole on segmented display W: segment width $\Phi = (A+B)/2$</p>  <table border="1" data-bbox="807 763 1399 1088"> <thead> <tr> <th colspan="2">Acceptable quantity</th> </tr> <tr> <th>Width</th> <th>Quantity</th> </tr> </thead> <tbody> <tr> <td>$W \leq 0.4$</td> <td>$\Phi \leq 0.2$ and $\Phi \leq 1/2W$</td> </tr> <tr> <td>$W > 0.4$</td> <td>$\Phi \leq 0.25$ and $\Phi \leq 1/3W$</td> </tr> <tr> <td colspan="2">Total acceptable quantity: 1 defect per segment Pin holes with Φ under 0.10 mm are acceptable</td> </tr> </tbody> </table> <p>4.2 Pin hole on</p>  <table border="1" data-bbox="1010 1162 1399 1601"> <thead> <tr> <th colspan="2">Acceptable quantity</th> </tr> <tr> <th>Size</th> <th>Quantity</th> </tr> </thead> <tbody> <tr> <td>$a, b < 0.1$</td> <td>Any number</td> </tr> <tr> <td>$(a+b)/2 \leq 0.1$</td> <td>Any number</td> </tr> <tr> <td>$0.5 < \Phi < 1.0$</td> <td>3</td> </tr> </tbody> </table> <p>4.3 Segments / dots with different</p>  <p>4.4 Alignment layer defect $\Phi = (A+B)/2$</p> <table border="1" data-bbox="963 1601 1319 1697"> <thead> <tr> <th colspan="2">Acceptable</th> </tr> </thead> <tbody> <tr> <td>$a \geq b$</td> <td>$a/b \leq 4/3$</td> </tr> <tr> <td>$a < b$</td> <td>$a/b > 4/3$</td> </tr> </tbody> </table>	Acceptable quantity		Width	Quantity	$W \leq 0.4$	$\Phi \leq 0.2$ and $\Phi \leq 1/2W$	$W > 0.4$	$\Phi \leq 0.25$ and $\Phi \leq 1/3W$	Total acceptable quantity: 1 defect per segment Pin holes with Φ under 0.10 mm are acceptable		Acceptable quantity		Size	Quantity	$a, b < 0.1$	Any number	$(a+b)/2 \leq 0.1$	Any number	$0.5 < \Phi < 1.0$	3	Acceptable		$a \geq b$	$a/b \leq 4/3$	$a < b$	$a/b > 4/3$
Acceptable quantity																												
Width	Quantity																											
$W \leq 0.4$	$\Phi \leq 0.2$ and $\Phi \leq 1/2W$																											
$W > 0.4$	$\Phi \leq 0.25$ and $\Phi \leq 1/3W$																											
Total acceptable quantity: 1 defect per segment Pin holes with Φ under 0.10 mm are acceptable																												
Acceptable quantity																												
Size	Quantity																											
$a, b < 0.1$	Any number																											
$(a+b)/2 \leq 0.1$	Any number																											
$0.5 < \Phi < 1.0$	3																											
Acceptable																												
$a \geq b$	$a/b \leq 4/3$																											
$a < b$	$a/b > 4/3$																											

Product Specification

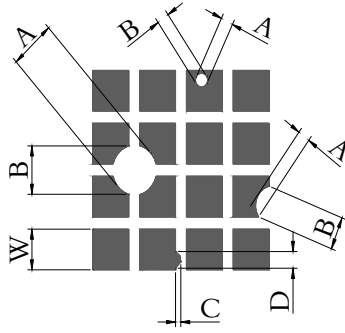
		 <p style="text-align: center;">Total acceptable quantity: 7</p>	<table border="1" style="margin-left: auto; margin-right: auto;"> <thead> <tr> <th colspan="2">Acceptable quantity</th> </tr> <tr> <th>Size</th> <th>Quantity</th> </tr> </thead> <tbody> <tr> <td>$\Phi \leq 0.4$</td> <td style="text-align: center;">Any number</td> </tr> <tr> <td>$0.4 < \Phi \leq 1.0$</td> <td style="text-align: center;">5</td> </tr> <tr> <td>$1.0 < \Phi \leq 1.5$</td> <td style="text-align: center;">3</td> </tr> <tr> <td>$1.5 < \Phi \leq 2.0$</td> <td style="text-align: center;">2</td> </tr> </tbody> </table>	Acceptable quantity		Size	Quantity	$\Phi \leq 0.4$	Any number	$0.4 < \Phi \leq 1.0$	5	$1.0 < \Phi \leq 1.5$	3	$1.5 < \Phi \leq 2.0$	2				
Acceptable quantity																			
Size	Quantity																		
$\Phi \leq 0.4$	Any number																		
$0.4 < \Phi \leq 1.0$	5																		
$1.0 < \Phi \leq 1.5$	3																		
$1.5 < \Phi \leq 2.0$	2																		
5	Colour uniformity	Level of sample for approval set as limit sample																	
6	Backlight	The backlight colour should correspond to the product specification Flashing and or unlit backlight is not allowed Dust larger than 0.25 mm is not allowed																	
7	COB	Exposed wire bond pad is not allowed Insufficient covering with resin is not allowed (wire bond line exposed) Dust or bubble on the resin are not allowed																	
8	PCB	No unmelted solder paste should be present on PCB Cold solder joints, missing solder connections, or oxidation are not allowed No residue or solder balls on PCB are allowed Short circuits on components are not allowed																	
9	Tray particles	<table border="1" style="margin-left: auto; margin-right: auto;"> <thead> <tr> <th colspan="3">Acceptable quantity</th> </tr> <tr> <th></th> <th>Size</th> <th>Quantity</th> </tr> </thead> <tbody> <tr> <td rowspan="2" style="text-align: center; vertical-align: middle;">On tray</td> <td style="text-align: center;">$\Phi < 0.2$</td> <td style="text-align: center;">Any number</td> </tr> <tr> <td style="text-align: center;">$\Phi > 0.25$</td> <td style="text-align: center;">4</td> </tr> <tr> <td rowspan="2" style="text-align: center; vertical-align: middle;">On display</td> <td style="text-align: center;">$\Phi \geq 0.25$</td> <td style="text-align: center;">2</td> </tr> <tr> <td style="text-align: center;">$L = 3$</td> <td style="text-align: center;">1</td> </tr> </tbody> </table>		Acceptable quantity				Size	Quantity	On tray	$\Phi < 0.2$	Any number	$\Phi > 0.25$	4	On display	$\Phi \geq 0.25$	2	$L = 3$	1
Acceptable quantity																			
	Size	Quantity																	
On tray	$\Phi < 0.2$	Any number																	
	$\Phi > 0.25$	4																	
On display	$\Phi \geq 0.25$	2																	
	$L = 3$	1																	

12. LCD MODULES HANDLING PRECAUTIONS

- Please remove the protection foil of polarizer before using.
- The display panel is made of glass. Do not subject it to a mechanical shock by dropping it from a high place, etc.
- If the display panel is damaged and the liquid crystal substance inside it leaks out, do not get any in your mouth. If the substance come into contact with your skin or clothes promptly wash it off using soap and water.
- Do not apply excessive force to the display surface or the adjoining areas since this may cause the color tone to vary.
- The polarizer covering the display surface of the LCD module is soft and easily scratched. Handle this polarize carefully.
- To prevent destruction of the elements by static electricity, be careful to maintain an optimum work environment.
 - Be sure to ground the body when handling the LCD module.
 - Tools required for assembly, such as soldering irons, must be properly grounded.
 - To reduce the amount of static electricity generated, do not conduct assembly and other work under dry conditions.
 - The LCD module is coated with a film to protect the display surface. Exercise care when peeling off this protective film since static electricity may be generated.
- Storage precautions
When storing the LCD modules, avoid exposure to direct sunlight or to the light of fluorescent lamps. Keep the modules in bags designed to prevent static electricity charging under low temperature / normal humidity conditions (avoid high temperature / high humidity and low temperatures below 0°C). Whenever possible, the LCD modules should be stored in the same conditions in which they were shipped from our company.

13. OTHERS

- Liquid crystals solidify at low temperature (below the storage temperature range) leading to defective orientation of liquid crystal or the generation of air bubbles (black or white). Air bubbles may also be generated if the module is subjected to a strong shock at a low temperature.
- If the LCD modules have been operating for a long time showing the same display patterns may remain on the screen as ghost images and a slight contrast irregularity may also appear. Abnormal operating status can be resumed to be normal condition by suspending use for some time. It should be noted that this phenomena does not adversely affect performance reliability.
- To minimize the performance degradation of the LCD modules resulting from caused by static electricity, etc. exercise care to avoid holding the following sections when handling the modules:
 - Exposed area of the printed circuit board
 - Terminal electrode sections